

# MX15 Series— Modular Incremental Rotary Optical Encoder

BEI Sensors



By the time you have read this first sentence, you could have installed BEI's model MX15 INSTA-MOUNT™ modular optical encoder. In addition to its quick and easy installation, the MX15 is designed to operate with jitter-free output signals without tight controls on shaft endplay, runout or perpendicularity. The new INSTA-MOUNT™ encoder is capable of operating within a temperature range of -10° to +70°C, requiring less than 30 milliamps of L.E.D. current, without degradation of output signals and is short circuit protected. The MX15 is perfectly suited for motor manufacturers and other high volume OEMs.

BEI's INSTA-MOUNT™ Series encoder offers 5V TTL compatible quadrature outputs with index and complements as options. Axial shaft movements during operation, of ±0.010", will not adversely affect the output signals. Shaft run outs of 0.005" TIR can also be absorbed by this device without affecting output signal performance.

## Mechanical Specifications

**Dimensions:** See Figure 1  
**Weight:** 2.0 oz.  
**Moment of Inertia:**  $2.6 \times 10^{-5}$  oz in sec<sup>2</sup>  
**Bore Size:** see "Ordering Options"

## Motor Interface

**Mount Holes:** #2-56 threads @ 180° on 1.280 dia. B.C.  
**Mount Hardware:** #2-56 x 3/4 in. (provided)  
**Perpendicularity Shaft to Mount:** ±0.0002" TIR  
**Shaft Runout:** 0.005" max (each 0.0001 degrades accuracy by 0.5 arc minutes)  
**Shaft Endplay Dynamic or Static:** ±0.005"  
**Shaft Finish:** 16 micro inches or better. End must be chamfered or rounded  
**Shaft Tolerance:** 0.0002"/-0.0007" (e.g. Ø32493/.2498)  
**Shaft Length:** 0.45" minimum remove (remove cover button for motor through-shafts)

## Electrical Specifications

**Code:** Incremental  
**Pulses per revolutions (PPR):** See "Ordering Options"  
**Index Pulse Options:** ungated index (U) (no index on MX152) gated index (G)  
**Supply Voltage:** 5 volts ±5% @ 80mA max.  
**Output Format:** dual channel quadrature & index (MX152 & 153) (no index on MX152) (MX156) dual channel quad & index w/ comps  
**Output Type:** (MX152 & 153): square wave TTL. 16mA sink 500ΩA source. Short circuit protected (MX156): TTL differential line driver (26LS31 or equiv.) should be terminated into a line receiver (26LS32, or equivalent circuit)  
**Frequency Response:** see graph: Fig 3  
**Rise Time:** 1.0μ sec. max.

## Environmental Specifications

**Temperature:**  
 Operating: -10°C to +70°C  
 Storage: -40°C to +125°C  
**Enclosure:** unsealed housing units must be protected from harsh environments

## Termination Specifications

**Terminal Board (Header):**  
 (MX152 & 153): See Pinout MX152 & 153  
 (MX156): See Pinout MX156  
**Round Shielded Cable:**  
 (MX152 & 153): See Color Code MX152 & 153  
 (MX156): See Color Code MX156

## MX15 Series Encoder Ordering Options: for assistance, call 800.350.2727

Use this diagram, working from left to right to construct your model number (example: **MX153-25-500-G-C18**)

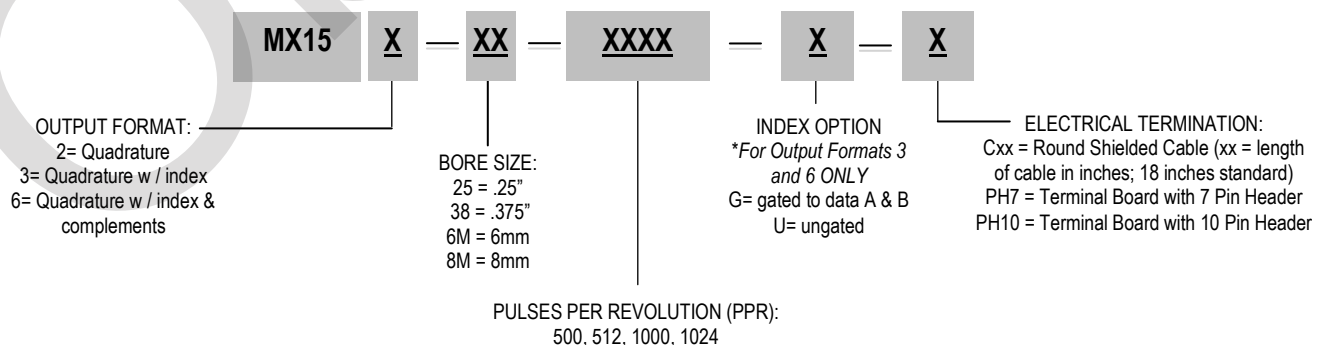

# MX15 Series— Modular Incremental Rotary Optical Encoder

BEI Sensors

## Dimensions

**Figure 1**

(MX152/MX153)

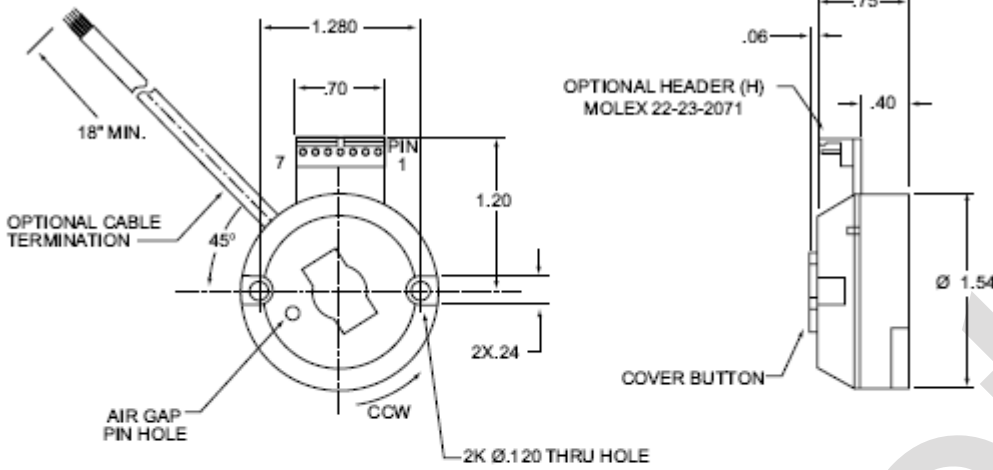

**Figure 2**

(MX156)

Dimensions not shown, same as Figure 1

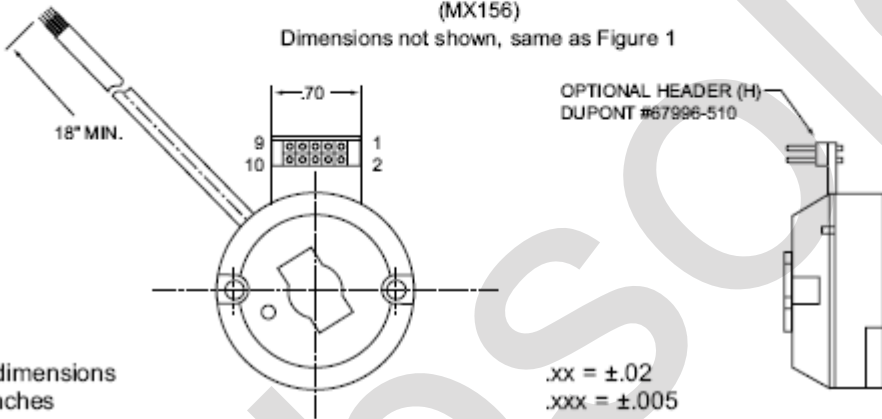

All dimensions in inches

## Terminations

### Terminal Board (Header)

PINOUT: MX152 & MX153

Pin #	Signal	Pin #	Signal
1	NC	5	Data B
2	Index (MX153)	6	Data A
3	NC	7	ground
4	+5 volt		

PINOUT: MX156

Pin #	Signal	Pin #	Signal
1	+5 volt	6	Data A̅
2	+5 volts	7	Ground
3	Index	8	Ground
4	Index	9	Data B
5	Data A	10	Data B̅

## Output

### Waveform

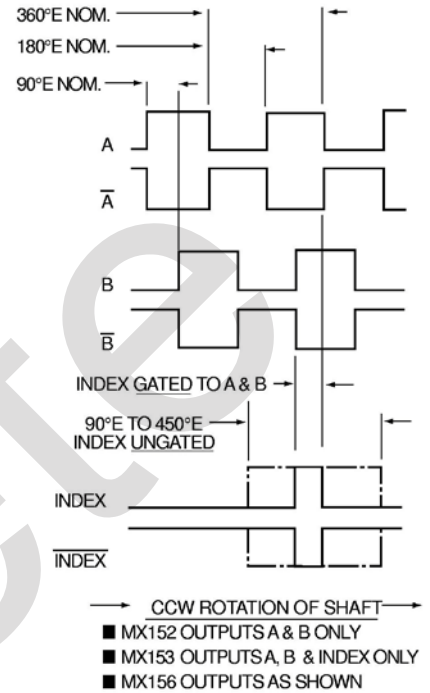

**Figure 3**

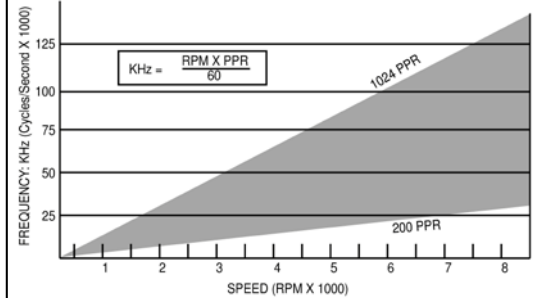

### Round Shielded Cable

COLOR CODE: MX152 & MX153

Color	Function	Color	Function
Red	+5 volt	Green	Data B
Black	Ground	Orange	Index(MX153)
White	Data A		

COLOR CODE: MX156

Color	Function	Color	Function
Red	+5 volt	Green	Data B
Black	Ground	Wht/Blk	Data B
White	Data A	Orange	Index
Blue	Data A	Red/Blk	Index

## Installation Instructions for MX15 Series Encoders

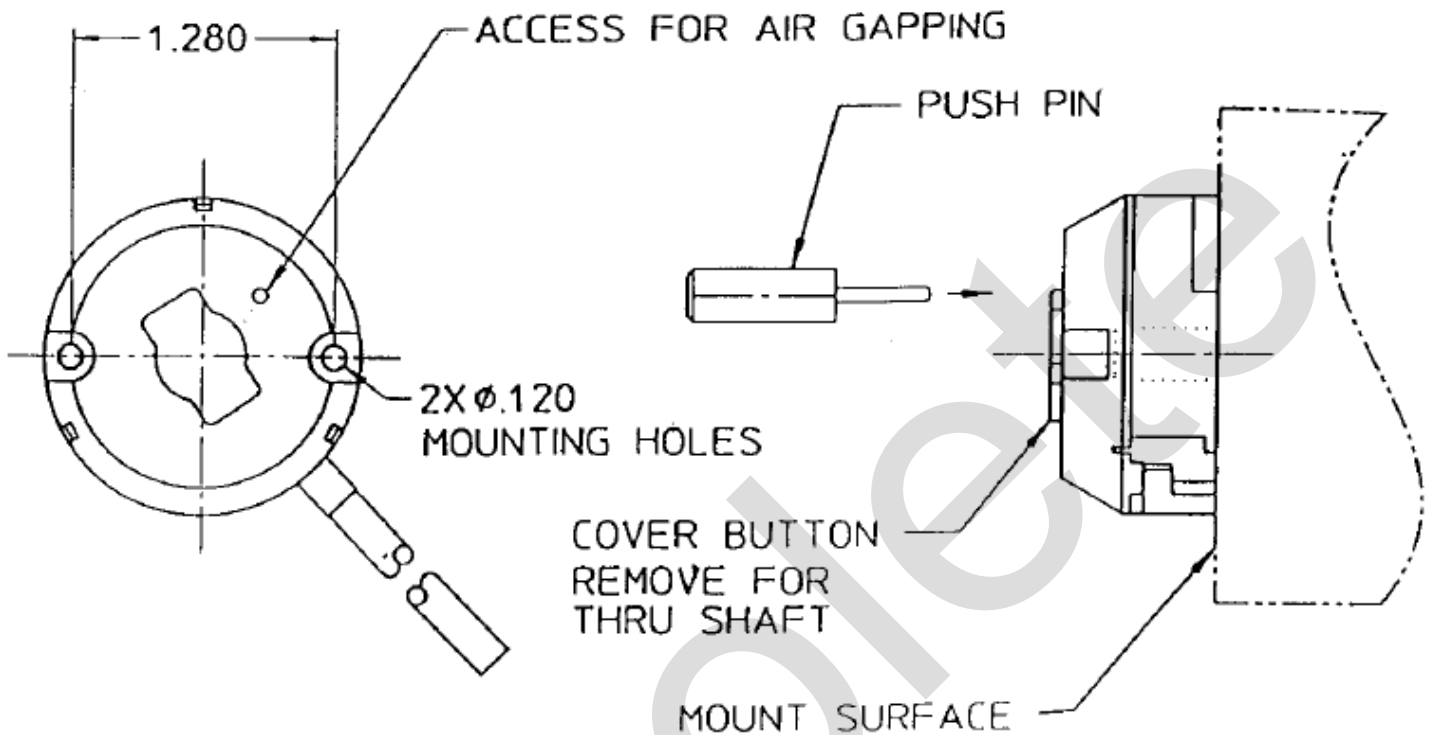

### Preparation:

1. Inspect motor interface per MX15 Data Sheet or specification drawing.
2. Motor shaft must be free of burrs and other surface defects.

### Installation:

1. Motor shaft should NOT be rotating during initial encoder installation.
2. Hold encoder perpendicular to motor shaft. Guide the encoder onto the motor shaft, pushing encoder STRAIGHT on until it is flush against the motor surface. Do NOT rock side to side.
3. Install two #2-56 mount screws. Do not fully tighten at this point. (Note: A thread sealant should be applied to the screw threads.)
4. Rotate the motor shaft (300 RPM, minimum). Insert push pin into the 1/16 hole in top of encoder and press until pin bottoms out on encoder cover momentarily, then remove pin. CAUTION: DO NOT press the push pin while motor shaft is stationary. Pin should only be pressed for one or two seconds while shaft is rotating.
5. Fully tighten mounting screws. (recommended torque is 20 to 25 ounce inches.)
6. This completes the mechanical installation. Proceed with electrical connections as indicated on product data sheet or specification drawing.

### Removal:

1. Motor shaft may be stationary or rotating up to 1000 RPM during encoder removal.
2. Remove two mounting screws.
3. Grasp encoder firmly and pull STRAIGHT off the motor shaft. Do NOT rock side to side.

These commodities, technology or software if exported from the United States must be in accordance with the Bureau of Industry, and Security, Export Administration regulations. Diversion contrary to U.S law is prohibited.